

**P
E
A
K**

**PEAK
P1 [E]**

Coffee Roaster
User Manual

P E  K

**More Intelligence
Better Performance**

[Contents]

Important information

Safety	01
Qualification	01
Personal protection	02
Fire prevention	02

Roaster parameters

Working Environment	02
Roaster Data	03
Electrical Data	03

Overview

Working Principle	04
-------------------------	----

Coffee Roaster Components

Coffee Roaster Control Panel

Display Screen Interface

Size Drawing

Installation and Adjustment

Installation Space	10
Installation & Connections	11

Safety

Smoldering Fire	13
Power Failure	13
Hot Surface Burns	13
Never Touch Hot Surfaces	14

Preparing for Production

Power On	14
Startup	14
Begin Roasting	14
Roasting Stages	15
Roast Levels	17
Common Roast Milestones	18
Key Roasting Insights	19

Troubleshooting Guide

Malfunction	21
Maintenance	22
Cleaning Schedule	23
Lubrication Schedule	24
Preventive Maintenance	24

Important information

Any problems, please contact the manufacturer or the local distributor.

Safety

The machine is only suitable for roasting cleaned green coffee beans with a dust content below 1% and a minimum bean size of 5mm.

The maximum processing capacity per batch is 1.2kg.

Operation in explosive risky areas is strictly prohibited.

Use the machine strictly in accordance with the guidelines.

Contaminated green coffee beans may still pose health risks even after roasting.

Green coffee beans should be stored in a dry environment.

Moldy green coffee beans must not be used.

When the machine is used under harsh conditions, there is a possibility of safety and functional impairment.

Pay attention to the maintenance and care of the machine.

If the equipment is not working properly, stop immediately and conduct an inspection.

Do not modify or reconfigure the equipment without authorization.

Qualification

Due to potential hazards of the equipment, operators should be well-trained.

Operators must maintain safety awareness and strictly follow operating procedures during work.

Operators working on mechanical equipment must complete technical training courses.

Operators working on electrical equipment must complete mandatory technical training courses.

Personal protection

Hot machine components during operation may cause burns.

When handling heated machine parts, protective equipment must be worn, such as heat-resistant gloves, protective clothing, etc.

Fire prevention

Excessively high material temperatures or flammable substances during operation may cause fires.

Ensure all staff have taken necessary fire prevention measures.

Maintain accessible fire water supply connections.

Keep fire extinguishers available near the machine.

Clearly display fire prevention protocols in visible locations.

Roaster parameters

Working Environment

Name	Value
Operating temperature	0-40°C
Relative humidity	< 95%

Roaster Data

Name	Value
Machine size	1250x500x750mm
Total machine weigh	120kg
Heater heat value	≈5000J/h
Electric power consumption	0-5.5Kw/h
Hot air fan exhaust	3.9m ³ /min
Cooling fan exhaust	9.9m ³ /min
Exhaust air temperature	≥ 200°C
Emissions of dust	< 50mg/ m ³
Diameter of hot air exhaust pipe	80mm
Cooling exhaust pipe diameter	80mm

Electrical Data

Name	Value
Total power of roaster	5500W
Drum power	90W
Drum speed	32-79(adjustable)rpm
Exhaust fan power	6W
Cooling fan power	18rpm
Smoke extraction fan power	60W
Cooling exhaust pipe diameter	240W

Overview

Working Principle

Roasting

Green coffee beans are roasted in the roasting drum and then cooled in the cooling tray.

Starting the Roaster

The roasting drum rotates.

The hot air fan operates.

Preheating

Press the heating button to start heating.

Click "Preheat" and the machine begins preheating.

During preheating, the heater warms the drum on one side while heating air on the other side, then directs the hot air into the drum.

Manual Roasting

Once the preheating temperature is reached, the green beans enter the roasting drum from the hopper.

The drum and hot air work together to heat the beans until they reach the temperature.

And then the cooling tray activates the cooling fan and stirrer start running.

Manually transfer the beans into the cooling tray.

The stirrer mixes the beans while the cooling fan cools them.

Once cooling is complete, open the discharge port to release the beans and turn off the cooling tray.

Note:

Roasting and cooling can occur simultaneously.

Automatic Roasting

Select a saved roast profile and click "Preheat."

Once preheating is complete, click "Start Roasting" to automatically load the beans.

The system replicates the roast curve automatically.

When the discharge temperature is reached, roasting ends automatically, the discharge door opens, and cooling begins.

Coffee Roaster Components

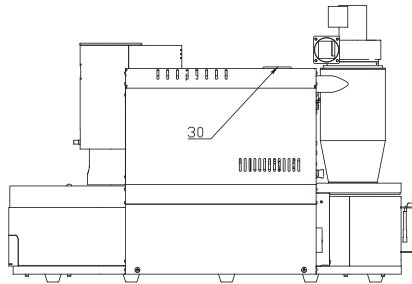
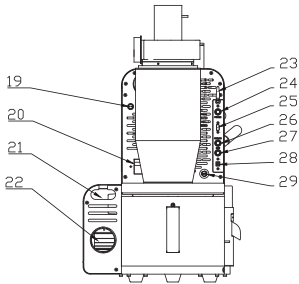
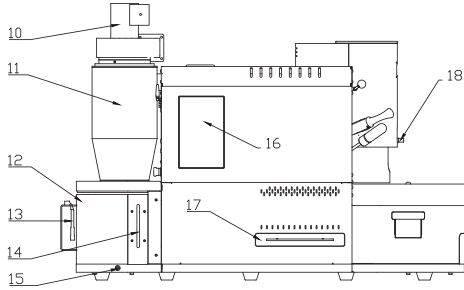
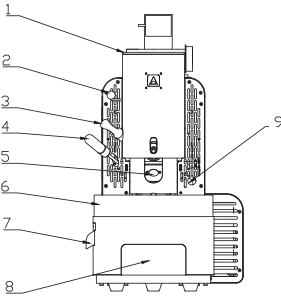

- ① Bean Hopper
- ② Bean Charging Handle
- ③ Sampling Probe
- ④ Discharge Handle
- ⑤ Viewing Window
- ⑥ Cooling Tray
- ⑦ Discharge Door
- ⑧ Chaff Collection Box
- ⑨ Flame Viewing Window
- ⑩ Variable-Frequency Hot Air Fan
- ⑪ Chaff Cyclone Barrel
- ⑫ Chaff Collection Bucket
- ⑬ Bucket Lock Key
- ⑭ Chaff Viewing Window
- ⑮ Bucket Lock Key Slot
- ⑯ Control Screen
- ⑰ Ash Tray
- ⑱ Hot Air Fan Port
- ⑲ Air Switch
- ⑳ Storage Compartment
- ㉑ Cooling Exhaust Pipe
- ㉒ Wi-Fi Antenna
- ㉓ Power Button
- ㉔ HDMI Port
- ㉕ Cooling Button
- ㉖ Stirring Button
- ㉗ USB Port
- ㉘ Emergency Stop Button
- ㉙ Variable-Speed Drum Motor

Coffee Roaster Control Panel

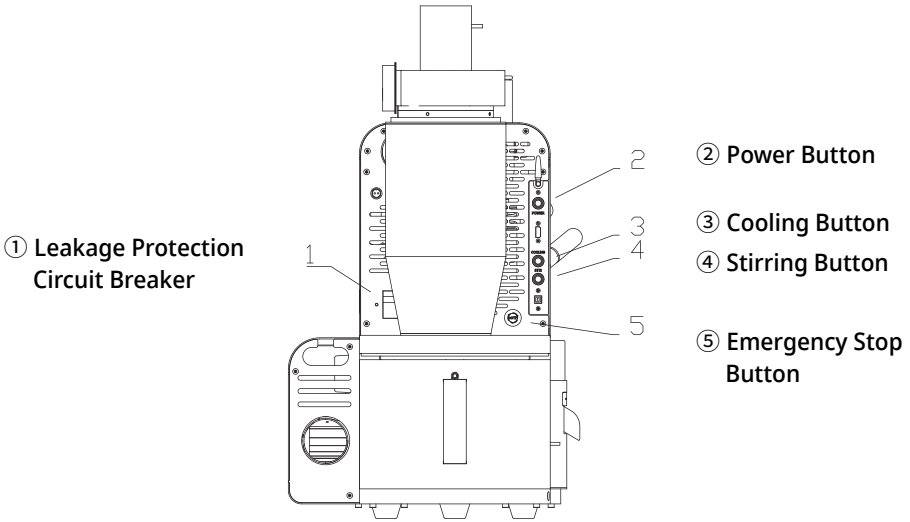

In case of any emergency, press the Emergency Stop Button immediately to stop the machine at any time.

After completing the roast cycle, turn off the Leakage Protection Circuit Breaker.

Power Button

Press to start the roaster. A white ring-shaped indicator light will illuminate.

Note: Maintain pressure on the button slightly longer than a typical tap to prevent accidental activation, as required by the system's anti-misoperation design.

Cooling Button

Activates the cooling fan.

Stirring Button

Engages the stirring motor.

Display Screen Interface

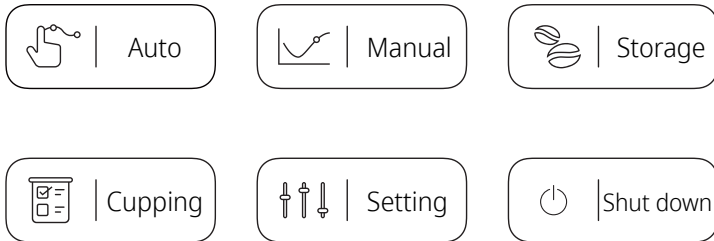

PEAK sys features 6 functional modules

Manual Roasting

Real-time display of 4-channel temperature monitoring.

Automatic roast profile recording.

Instant control over all component switches.

Automatic Roasting

View all saved roast profiles.

Select any profile for automated reproduction.

Inventory Management

Add green coffee origin information.

Real-time bean stock monitoring.

Cupping Analysis

Access all cupping evaluations correlated with each roast profile.

Real-time quality assessment tracking.

System Configuration

Roasting environment parameters setup.

Equipment diagnostic testing.

Machine cleaning maintenance.

System Shutdown

Emergency forced shutdown.

Cool-down sequence & power off.

Size Drawing (mm)

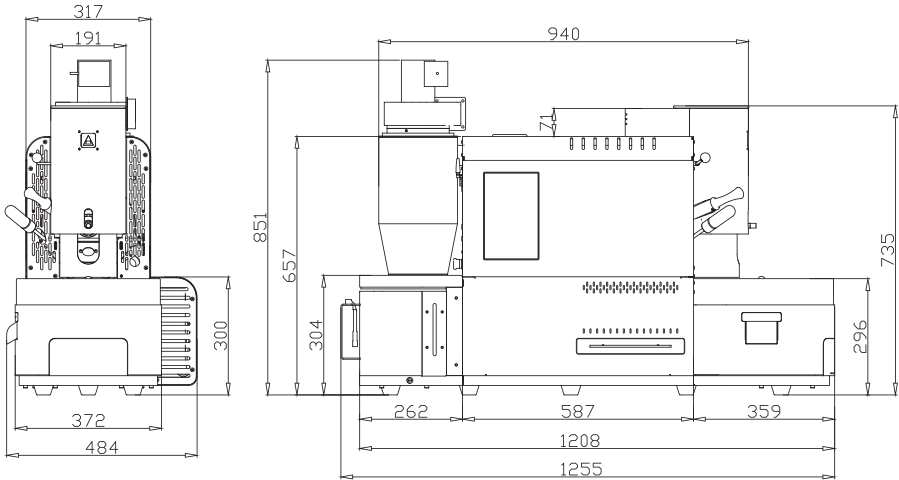

Installation and Adjustment

Installation Space

Ensure the roaster is installed with the minimum required clearance space, allowing sufficient working area.

Some certified fire extinguishers must be placed nearby.

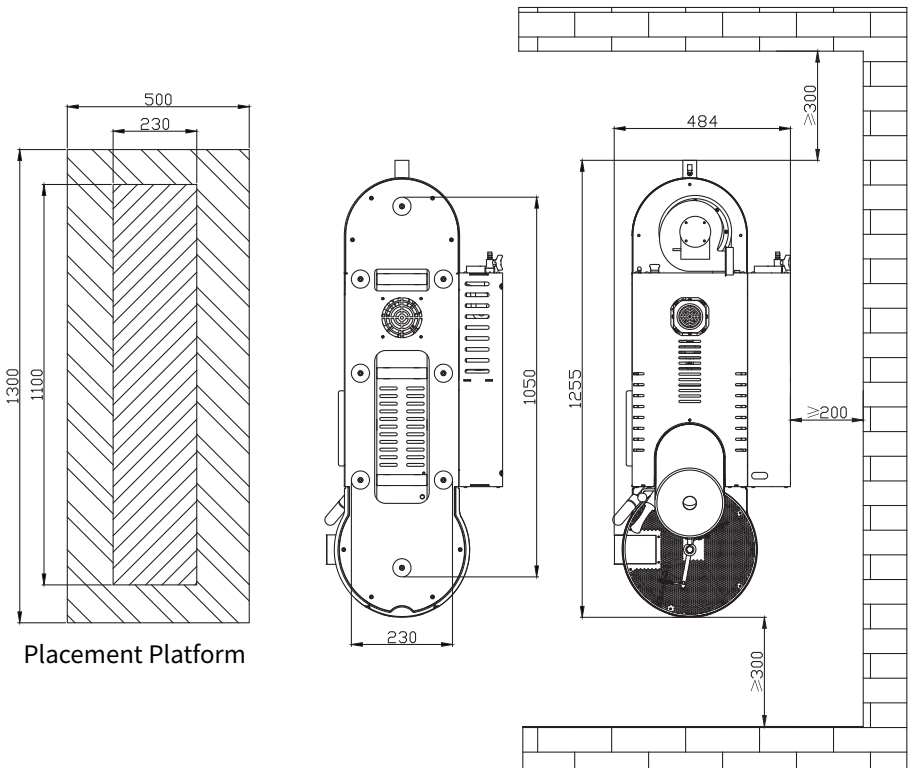

Installation & Connections

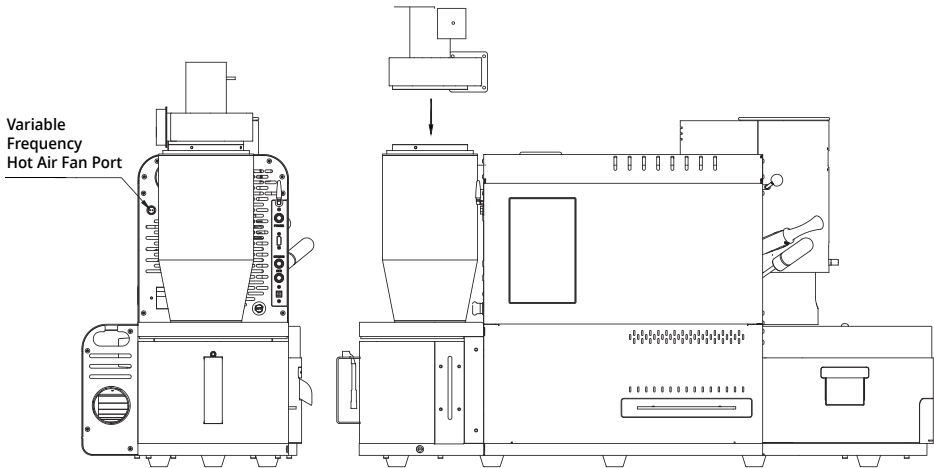

Roaster Installation

Connect the body to the chaff collection barrel.

Adjust the air outlet direction of the barrel.

Exhaust Duct Connection

Hot Air Duct Installation:

Use 80mm diameter metal ducting or high-temperature resistant hose, Connect one end to the roaster's hot air blower outlet, Connect the other end to an air purification system before outdoor venting.

Cooling Air Duct Installation

Use 80mm diameter metal ducting or high-temperature resistant hose, Connect one end to the roaster's cooling exhaust port, Connect the other end to an air purification system before outdoor venting.

Note:

Install air purification systems if local emissions regulation requires.

Electrical Connection

Connect the blower's power cable to the main unit.

> Secure with the locking ring (clockwise rotation)

> Plug in and verify proper grounding continuity

Power Cable Connection

380V, three-phase.

Connect each wire to the corresponding terminals in the control box according to the wire labels.

Check the installation	Check✓
Roaster placed firmly	()
Chaff collection bucket fixed	()
Hot air fan fixed	()
Fire appliances available	()
Electrical appliances connected	()
Exhaust pipe installed	()

Safety

If the bean temperature exceeds +250°C, coffee beans may self-ignite, causing injuries.

- > *Shut off heating immediately.*
- > *Discharge and cool beans rapidly.*
- > *Water spray to extinguish if necessary.*

Smoldering Fire

Combustible materials (e.g., chaff) in the collection barrel, exhaust pipes, or ducts may smolder.

- > Ensure pure green coffee contains no other things.
- > Empty the chaff collection barrel timely.

Power Failure

A sudden cutoff of Electricity could cause coffee beans smolder and operator injury due to high temperature.

- > Open the discharge door.
- > Manually rotate the drum using the provided stirring tool.
(it is in the tool bag included with the roaster)
- > Monitor bean temperature and take cooling measures if necessary.

Hot Surface Burns

Bean hopper, exhaust pipes, chaff collection barrel, roasting drum and burner. Chamber could potentially reach extreme temperatures.

Never Touch Hot Surfaces

Wear heat-resistant gloves during maintenance.

Keep flammable materials away from the machine.

Preparing for Production

Power On

Turn the air switch to the "ON" position.

Note:

Ensure the power is properly connected, and both the bean intake gate and discharge door are securely closed before proceeding.

Startup

Press the "Power" button to start the roaster.

Open the liquefied gas tank valve.

Begin Roasting

Press the "Heating" switch to begin preheating the machine.

Adjust the heat intensity by sliding the dial to select the desired value displayed on the "Heating" panel.

Preheating is required before each roast. This allows the roaster to reach optimal working conditions and adapt to the coffee roasting process. Preheating time varies depending on heat intensity and airflow settings.

Select an appropriate preheating temperature based on the batch size.

Roasting Stages

A typical coffee roasting process includes the following stages:

Preheating → Drying → Yellowing → First Crack → End of First Crack → Second Crack → Cooling

Adjust timing and roast level based on the coffee being roasted.

Note: Never leave the roaster unattended during the entire process. Continuous monitoring is required to prevent roasting failures or fire hazards.

Preheating

After preheating the machine, load the green beans into the bean hopper and open the intake gate. The beans will automatically drop into the roasting chamber. Once all beans have entered, close the intake gate.

At the moment beans enter the chamber, their specific heat capacity is at its highest, meaning they require maximum heat input to rise in temperature.

Do not worry about scorching the beans early on-preheating ensures rapid temperature rise, saving time in the initial phase.

End of Drying Phase / Yellowing

At 150-160°C, the beans undergo visible changes: color shifts from green to pale yellow, and aromas transform dramatically. Chemical reactions are about to begin.

The line between under-drying and over-drying is thin. Visual cues alone are insufficient-smell is essential.

Under-dried beans (high moisture) → astringent taste.

Over-dried beans → muted first crack and flat flavor.

Look for the shift from "grassy" to "wheat-like" aromas.

Approaching First Crack

The beans now need intense heat to prepare for first crack. Steam escaping the fibers demands energy.

Maintain a rate of rise (RoR) of 10°C/min. Low heat here risks a weak first crack.

Approaching First Crack

First crack is an exothermic phase. As the beans's specific heat drops, reduce heat input to control the reaction-but avoid temperature stalls (which "freezes" the beans, ruining the roast).

Process Timeline:

Sporadic cracks → Rolling cracks → Sporadic again (typically 1.5-3 minutes).

Focus on RoR, not crack duration. Proper heat ensures even development, avoiding baked or underdeveloped flavors.

End of First Crack

A quiet period follows as beans resume heat absorption. Wrinkles smooth out, and aromas evolve. Many roasters drop beans here for cooling.

Do not increase heat if the temperature plateaus-it signals beans are prepping for second crack. Wait patiently.

Second Crack

Once second crack begins, it releases rapid, intense heat. Immediately lower or cut heat-beans are now lightweight and can overdevelop within seconds.

Act Fast, sample frequently; 5 seconds can drastically alter flavor.

Cooling

Pre-activate the cooling system before dropping beans. Open the discharge door, and roasted beans will auto-eject into the cooling tray.

Residual heat can cause over-roasting. Rapid cooling locks in flavor.

Once beans are fully cooled, open the tray's outlet to release them.

Roast Levels

Green Coffee

Unroasted beans appear green. Color changes with roast development.

Light Roast

The lightest roast level (wheat color).

No distinct aroma or bitterness when brewed-not suitable for drinking.

Cinnamon Roast

Slightly darker than Light Roast (cinnamon color).

Enhances acidity in high-quality beans.

Medium Roast

Chestnut brown. Balanced acidity and mild bitterness.

Ideal for American-style coffee with bright acidity.

High Roast

Rich brown. Acidity subdued; sweetness and bitterness intensify.

City Roast

Named after New York City.

Perfect equilibrium of acidity and bitterness.

Full City Roast

Darker than City. Almost no perceptible acidity.

French Roast

Shiny black surface (oils begin to emerge).

Used for café au lait and Vienna coffee.

Italian Roast

The darkest commercial roast.

Common Roast Milestones

Term	Stage Description
City-	Mid-to-late first crack (common for cupping)
City	End of first crack.
City+	30sec-1min after first crack (light single-origin roasts).
Full City-	1.5 min after first crack, just before second crack (soft-acidity beans).
Full City	Onset of second crack (first few pops).
Full City+	Early second crack (before intense stage; ideal for high-altitude hard beans).
Vienna	Mid-second crack (intense stage).

Agtron Range

Roast Level	Weight Loss	Roasting Stage Description
#69-#65Ultra-Light	8%-13%	Mid-to-late first crack (rolling cracks to tail end)
#69-#65Light	11%-14%	End of first crack
#64-#60Light-Medium	13%-15%	30-40s after first crack
#59-#55Medium	14%-16%	Near second crack; beans transition to endothermic phase
#54-#44Medium-Dark	16%-18%	20-40 sec into second crack (initial pops, exothermic)
#43-#36Dark	17%-19%	40-100 sec into second crack (intense stage: rapid, intense cracks)

#35-#26 Southern Italian	19%-21%	100 sec into second crack (late-stage cracks)
#25-#18 French	21%-23%	Second crack ends; smoke turns blue (high fire risk!)

Note:

The provided roast levels are approximate ranges and should be evaluated alongside aroma for comprehensive judgment.

Key Roasting Insights (Examples)

Dehydration Time vs. High-Temp Drop

Beans roasted to similar color profiles but with extended dehydration time versus rapid high-temperature quenching will develop entirely different flavors.

Bean Size (Screen Size Variation) Even within the same coffee variety, beans of different screen sizes, will taste distinct despite similar roast color-heat absorption varies.

Density Differences ("Soft" vs. "Hard" Beans)

Uniform roast profiles applied to low-density ("soft") and high-density ("hard") beans yield divergent results.

Processing Methods Matter

Washed, semi-washed, and natural-processed coffees require customized dehydration timing.

Slight underdevelopment or insufficient dehydration leads to off-flavors (e.g., grassy, astringent notes).

Fresh Crop vs. Aged Beans

Moisture content and freshness alter roast dynamics—identical profiles won't translate.

Roaster Type (Electric vs. Gas)

Gas roasters achieve steeper temperature curves compared to electric ones.

Heat Source Variations

Direct flame, semi-hot air, and full hot air systems produce markedly different flavors due to:

Temperature control

Smoke ventilation efficiency

Drum rotation speed

Heat stability

Airflow adjustment range

Post-roast cooling rate

Mastery demands iterative experimentation-every variable shapes the cup!

Shutdown

Turn off the "Heating" switch.

Empty the roasting drum.

Clear the cooling tray.

Wait until the machine's bean temperature cools to 50°C, then power off.

Troubleshooting Guide

Malfunction	Possible Cause	Solution
Roasting Process Too Slow	Excessive bean load in drum	Reduce bean quantity in next batch
	Insufficient heat output	Increase heat to required level
	Inadequate exhaust airflow	Gradually increase damper opening
	Excessive exhaust airflow	Gradually decrease damper opening
	Clogged exhaust fan/duct	Clear obstruction
	Exhaust fan not operating	Check power connection Inspect exhaust fan Replace if necessary
Roasting Process Too Fast	Insufficient bean load in drum	Increase bean quantity in next batch
	Excessive gas pressure	Reduce gas pressure to required level
Bean Quality Issues	Beans being sucked into system	Excessive airflow Gradually decrease damper opening
	High chaff content in roasted beans	Closed damper Gradually open damper Clogged fan/duct - clear obstruction Fan not operating - check power Inspect/replace fan if needed

Mechanical Issues	Grinding noise at front bearing	Dry bearing operation Lubricate drum shaft/bearing Inspect/replace bearing if needed
	Drum touching front panel	Insufficient drum clearance Adjust drum gap
	Coffee particle leakage	Excessive drum clearance Adjust drum gap
Cooling Stage Problems	Slow cooling	Clogged perforated plate - clean Clogged cooling fan/duct - clear obstruction Cooling fan not operating - check power Inspect/replace fan if needed
	Agitator not working	Motor failure Check power supply Inspect/replace motor if needed
Cooling Stage Problems	Excessive chaff in exhaust	Motor failure Check power supply Inspect/replace motor if needed

Maintenance

Safety Precautions

Always implement protective measures during maintenance to prevent accidents. Serious injury may occur if the machine is accidentally activated during service.

Mandatory Safety Steps

- Unplug the power cord
- Switch the air circuit breaker to OFF position

Cleaning Schedule

Frequency	Component	Procedure
Daily	Chaff collector	Empty chaff collection bin
	Broken bean drawer	Clear broken bean compartment
	Machine surfaces	Wipe with clean cloth and vacuum
3 Months	Cooling tray	Remove debris from perforated plate using sharp tools and vacuum
	Air damper	Disassemble and scrub with stiff brush
	Hot air fan	Remove and clean fan blades with stiff brush
	Exhaust ducts	Inspect and clean smoke pipes; replace if necessary
6 Months	Combustion chamber	Vacuum interior
	Chaff bucket	Vacuum interior surfaces
	Cooling tray interior	Thorough vacuum cleaning
	Bean hopper	Disassemble and clean internal components
Annually	Electrical cabinet	Open service panel and vacuum clean electrical components

Lubrication Schedule

Frequency	Component	Procedure
3 Months	Front/rear bearings	Apply minimal grease
	Hot air fan	Lubricate shaft and bearings with WD-40 silicone lubricant
	Cooling fan	Lubricate shaft and bearings with WD-40 silicone lubricant
	Cooling tray	Lubricate bean door push rod with WD-40 silicone lubricant
	Drum motor	Replace gearbox grease (use premium brand lubricant)
12 Months	Agitator motor	Replace gearbox grease (use premium brand lubricant)

Preventive Maintenance

Frequency	Component	Procedure
Daily	Bolts/nuts	Check tightness
	Roasting drum	Verify clearance between drum and front panel; adjust if needed
	Gas lines	Inspect condition; replace if necessary
	Visible cables	Check integrity; replace if damaged
Weekly	Exhaust pipes	Verify seal integrity
	External connections	Confirm all cable connections are secure
Monthly	Burner	Check gas supply pressure; adjust if required

3 Months	Temp sensors	Verify calibration at 100°C (boiling water); replace if $\pm 3^\circ\text{C}$ deviation
	Cooling paddles	Check angle alignment; adjust if necessary
	Safety devices	Test functionality
6 Months	Burner block	Inspect condition; replace if worn
	Exhaust fans	Test operation; replace if faulty
	Cooling fans	Test operation; replace if faulty
Annually	Drum paddles	Inspect for wear; replace if damaged
	Machine components	Verify functionality and re-calibrate

**You master roasting.
You bring the passion.
We bring the precision.**



Whats App



Official Account

Aiqubei Coffee Technology (Ningbo) Co., Ltd.

<http://www.hbroaster.com/>



HB

COFFEE ROASTER